



通过德国莱茵技术监督服务有限公司
ISO9001 质量管理体系认证

品名: 双门食具消毒柜

制造商: 广东康宝电器有限公司

地址: 广东省佛山市顺德区杏坛镇齐新路268号

全国服务热线: 4007000818

监制: 锦江麦德龙现购自运有限公司

地址: 上海市真北路1425号



双门食具消毒柜

Double-door Tableware Sterilizer

使用说明书

User Manual

(使用产品前请仔细阅读本使用说明书, 并妥善保存)

(Please read this manual carefully before using the product and keep it properly.)

型号/Type: RTP380E-7

容积/Volume: 284L

功率/Power: 1350W

目 次

一、警告	1
二、特别注意	1
三、注意事项	1
四、各部件名称	2
五、安装方法	3
六、主要技术参数	3
七、特点	3
八、使用方法	4
九、日常维护保养	4
十、维修服务	5
十一、产品保修卡	6
十二、产品安装维修记录表	7

感谢您使用HORECA SELECT系列产品。

RTP380E-7双门餐具消毒柜，上层以臭氧、中温方式保洁，下层以光波、远红外线高温方式消毒，能有效杀灭大肠杆菌、金黄色葡萄球菌及破坏乙肝病毒，消毒效果符合国家标准要求。是集集体饭堂、办公室、饭店、幼儿园等场所食具消毒、保洁、存放的理想器具。

警告

- 关好上层门后，才能使上层工作，否则会有臭氧泄漏。
- 不能把非食具放入消毒柜内。
- 在消毒柜工作结束20分钟后才能打开柜门，待食具冷却后才能取用，以免影响消毒效果、防止臭氧泄漏或烫伤。
- 不能把塑料及木制品食具放在下层高温柜内。
- 高温，小心烫伤。

特别注意

- 耐温低于75℃的食具不能置于本产品中消毒、烘干。
- 对耐温低于180℃的食具如耐高温塑料、硅橡胶制品和不耐高温的玻璃制品食具，不能放入下层进行消毒，只可放入上层。
- 耐温在180℃~250℃的食具高温消毒时应远离加热管100mm以上。

注意事项

- 电源插头必须有可靠的接地线，用户不得擅自改插头，禁止无接地运行；（见附图1）
- 安放碟架时请把盘碟等支架朝向内胆背部；（见附图2）
- 把食具上的水倒净或擦干后才能放进柜内。食具不宜重叠，应逐格竖放，可获最佳消毒效果；
- 工作过程中，请勿触摸门玻璃，以免烫手；
- 使用过程中，如出现故障或发现臭氧泄漏，应马上停止使用，切勿自行修理，应尽快通知本公司电器维修中心或代理商安排检查维修；
- 对特殊使用人群(如儿童等)不适合使用本器具；
- 使用过程中，出现异常情况(如异常噪声、气味、温度升高、烟雾等)应立即拔掉消毒柜的电源插头，并通知本公司电器维修中心或代理商安排检查维修；
- 指示灯灭后不宜立即取用下层食具，此时柜内仍处于高温状态，待降至较低温度时再行取用，以免烫伤；

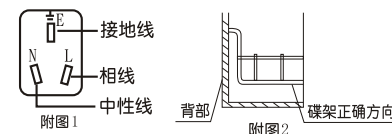

- 在消毒柜上层工作期间，打开上门，上层停止工作，关好上门后，需重新按上层键才能工作；
- 不要把排气孔堵住；
- 保养维护时，应首先拔下电源插头；
- 如果器具的电源软线损坏，必须由本公司电器维修中心或代理商安排专业人员来更换；
- 切勿将消毒柜安装在易燃物附近，亦不得将毛巾、衣物等放在柜内、柜上或旁边；
- 本产品为立式，请按安装方法置于水平干燥地面上；
- 消毒、保洁完成后，请将电源线插头拔下；
- 本器具的安全使用年限为10年(自购机之日起开始计算)；
- 废旧器具的处理方法：对于超出安全使用年限或不具备维修价值的废旧器具，请交给符合资质的回收企业、家电经销商或售后服务机构处理，用户不应擅自丢弃和从事拆解活动。

各部件名称

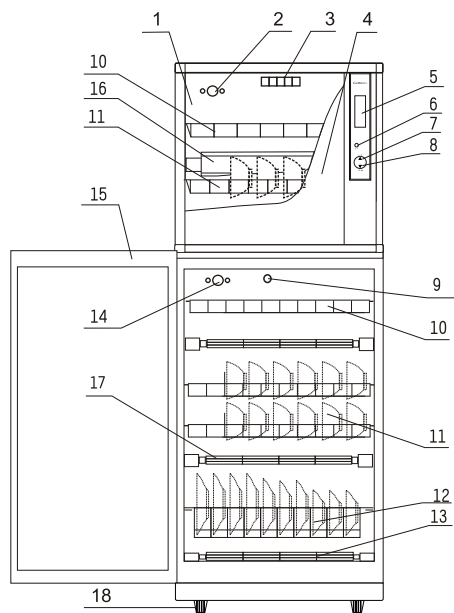

- 1、箱体
- 2、上层控温器
- 3、臭氧发生器
- 4、上门
- 5、显示屏
- 6、关断键
- 7、上层按键
- 8、下层按键
- 9、下层柜排气孔
- 10、杯架
- 11、碗架
- 12、碟架
- 13、远红外线加热管
- 14、下层控温器
- 15、下门
- 16、远红外线加热管
- 17、光波管
- 18、可调支脚

安装方法

将消毒柜置于水平干燥地面上，如放置不平请旋拧可调支脚进行调整，至平整为止。在离地面大约1568毫米高的位置（如图示），用M8×60的膨胀螺栓固紧“L”形件在墙上，“L”形件与箱体挂扣相配，固定牢靠。

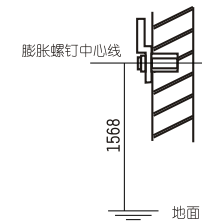

主要技术参数

产品型号	RTP380E-7	
电 源	220V~ 50Hz	
额定输入功率	1350W	
容 积	284L(上层90L, 下层194L)	
上 层	臭氧浓度	2mg/m ³ ≤ O ₃ 浓度 ≤ 30mg/m ³
	工作时间	≥10分钟
	臭氧发生器有效使用寿命	≥1000h
下 层	消毒星级	**
	消毒温度	125 ⁺⁴⁵ / ₋₅ °C
	工作时间	≥15分钟
	加热管有效使用寿命	≥5000h
	工作周期(负载)	≥30分钟
	每层层架承载额定重量	7kg
	净 重	46kg
	外形尺寸(长×宽×高)	555mm×515mm×1640mm
	执行标准	GB 17988-2008 Q/KB 16-2010
	企业标准备案号	QB/440606 97 9725-2010
	生产企业卫生许可证号	粤卫消证字[2002]第0008号

特 点

- 超时代感外形设计，脱俗新颖，别具一格。
- 不锈钢外壳，经久耐用。
- 上层臭氧烘干，适用于不耐温餐具的保洁与存放，并备有快速分解残余臭氧功能。
- 下层光波及远红外线加热至120℃以上高温消毒，对大肠杆菌、金黄色葡萄球菌杀灭率达99.9%以上，对乙肝表面抗原（HBsAg）的破坏呈阴性反应，对人体无任何副作用。

- 上下层温度控制准确，性能优良，并备有超高温保护及上层开门臭氧停止工作控制装置，安全可靠，可选择上、下层同时工作或上下层单独工作。

使用方法

- 首先插上电源插头，准备工作。
- 单独使用下层柜时，按下“下层”按键后，消毒指示灯亮，下层柜单独工作，当下层柜内温度高于控温器设定温度时，指示灯自动熄灭。
- 单独使用上层柜时，按下“上层”按键，臭氧烘干工作指示灯亮，上层柜的臭氧发生器和加热管同时工作，当柜内温度高于控温器设定温度时，指示灯自动熄灭。
- 若同时使用上下层柜时，则将“上层”、“下层”按键分别按下即可。
- 指示灯灭后20分钟仍在消毒，在这段时间内请不要开门，以免影响消毒效果。
- 若需中途停止各功能，请按“关断”键停止。
- 工作期间上层柜开门使上层停止工作后，必须关好门再按“上层”按键，上层才能继续工作。

日常维护保养

宜经常清洁保养，清洁时拔下电源插头，用湿毛巾蘸少许中性合成洗涤剂，轻轻擦去柜内外污渍，再用干净的湿毛巾擦去洗涤剂。

如果在使用过程中发生异常现象，应立即停止使用并拔下电源插头，非专业人员严禁对本机进行拆卸检查。

常见故障及处理方法如下：

常见故障	原因分析	处理方法
整机不工作	插头与插座接触不良	修理或更换
	超温熔断器或熔断器熔断	更换超温熔断器或熔断器
	电源线断路	更换电源线
臭氧发生器不工作	门控开关坏	更换门控开关
	继电器坏	更换继电器
	臭氧发生器坏	更换臭氧发生器
加热管不工作	继电器坏	更换继电器
	温控器坏	更换温控器
	加热管坏	更换加热管

维修服务

- 产品自购买日起一年内非人为造成的内部故障，本公司给予免费维修服务。
- 因使用不当，保养不善而损坏者，仍予以维修方便。请用户不要撕去消毒柜上的出厂编号，以便维修人员核实记录。
- 要求维修服务请与本公司售后服务部联络。

产品保修卡

NO.:

产品型号: _____ 机身条形码: _____

发票号码: _____ 购买日期: _____

用户姓名: _____ 电话号码: _____

住 址: _____

一、产品保修卡随每台产品附带，由顾客妥善保存，以作产品保修凭证，遗失不补。

二、产品包修规定

- 1、我公司产品的包修期为一年，包修期内我公司负责免费维修。
 - 2、包修期的判断：包修期的起始日以有效票据的购买日期为准，如果无法出示有效票据，则以产品条形码查核出厂日期加15天为起始包修日期。
 - 3、包修期内，如发生下列其中之一情况，均不属于免费维修范围：
 - (1) 不能提供有效购机票据；
 - (2) 没有按照说明书的要求安装或使用而造成产品故障；
 - (3) 自行维修、保养或使用不当造成损坏；
 - (4) 非产品质量问题，属人为造成的损坏；
 - 4、不属于免费维修范围的产品将按照保修期外的标准收费。
 - 5、维修时请出示《产品安装维修卡》及购机有效票据。
 - 6、质量问题的产品更换必须提供购机的有效票据复印件。
- 三、如用户对公司特约维修单位提供的服务不满意，可直接向本公司售后服务部投诉。

地址：广东省佛山市顺德区杏坛镇齐新路268号

电话：(0757) 27771526

传真：(0757) 27773237

邮编：528325

http://www.canbo.cn

E-mail:kbcd_service@canbo.cn

(如有更改，恕不另行通知)

产品安装维修记录表

产品名称		产品型号		
安装单位		安装日期		
产品条形码 (填写)				
维修日期	故障内容		维修单位	维修员
	故障情况	更换配件		

注意事项:

保修期内产品维修完后，由维修人员填写《产品安装维修记录表》中产品维修的内容。

Contents

Warning	8
Special attention	8
Precautions	8
Names of components	9
How to install	9
Major technical data	10
Features	10
How to use	10
Daily maintenance	11
Repair or maintenance service	11
Product warranty card	12
Warranty form	13

Thanks for using HORECA SELECT series products.

The RTP380E-7 Double-door Tableware Sterilizer keeps clean and dries the tableware and appliance disinfected with ozone, UV and mid-temperature in the upper layer and sterilize by far infrared in the lower layer. The product can kill colon bacillus, staphylococcus and bacteria causing hepatitis. The sterilizing result meets the national standards. It is an ideal dryer sterilizer for the restaurant, kindergarten, hotel, dining hall and other places.

Warning

- Only when the door is closed can the sterilizer work normally, otherwise there will be leak of ozone.
- Do not put any other thing than tableware into the sterilizer.
- In order to achieve the best disinfection result and avoid burning your hands or leak of ozone, you are suggested to wait for another 20mins before opening the door after the sterilizing is finished and do not take out the tableware before they cool down.
- Can not put the plastic and wooden product into the lower layer.
- High temperature, please be careful not to get burnt.

Special attention

- For the table ware of which heat-resistance is below 75℃ should not be placed in the cabinet.
- For the tableware of which heat-resistance is below 180℃, such as high temperature resistance plastic materials, silicon rubber product or low temperature resistant glass products should not be put into the lower layer.
- The tableware of which heat-resistance is between 180℃ to 250℃ should be put away from the heat pipe about 100mm.

Precautions

- The power supply socket must be reliably ground. The user should not change the socket by himself.(Please refer to picture 1)
- When placing the racks, the dish rack should be facing the back of the inner cabinet.(Please refer to picture 2)

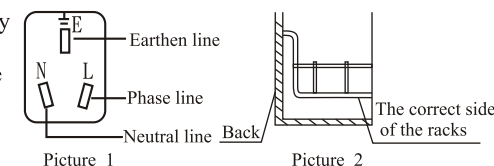

- The tableware should be dry before putting into the cabinet and shouldn't be overlapped to obtain the best sterilizing effect.
- Don't touch the glass of the door when it is sterilizing for avoiding being scalded.
- If any break-down or leak of ozone or any problem is found, please inform the service center or authorized agents to arrange repairs.
- To the especial people (such as children) are not adapt to use this product.
- If the abnormal state (such as abnormal sounds, odor, heat up, smog) appear while use the product, the user should pull the plug out and inform the service centre of the company or the agent to arrange the inspection.
- When the instructor lights are off, you should not take out the tableware right away as the temperature in the inner cabinet is still very high and to avoid burning your hand. You are suggested to take them after the temperature goes down.
- When the upper layer is sterilizing, it will stop working if open the upper door. After close the door and press the "upper layer" button it will work again.
- Don't block the Air-off hole.
- When the maintenance work is required, the power supply should be turned off first.

- If the power supply wire is damaged, our service center or authorized agent should be informed to make the repairs.
- Don't put the sterilizer near the flammable products and the cloths things are not allowed to put into, on or beside the cabinet.
- This product is vertical mode, please put on the dry ground according to the install method.
- Please turn off the power supply after sterilizing.
- This appliance safe use term is 10 years (from the date of the user bought).
- How to deal with the appliance out of date: As to the appliance out of date or without any maintainable value, please deliver the product to the eligible recycle company, home appliance distributor or the after-sales service department. The user should not throw away or break up the appliance by themselves.

Names of components

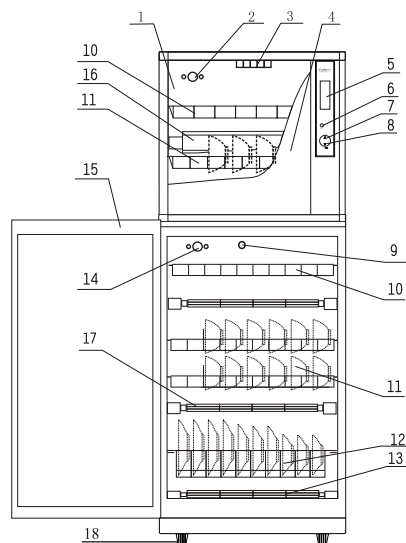

1. Body of the cabinet
2. The upper layer temperature control
3. O3 producer
4. The upper door
5. Display
6. Off button
7. The lower layer button
8. The upper layer button
9. Air-hole
10. Cup rack
11. Bowl rack
12. Dish rack
13. Heat pipe
14. The lower layer temperature control
15. The lower door
16. Heat pipe
17. Light-wave pipe
18. Adjustable foot

How to install

- Put the sterilizer on the ground. You can tweak the adjustable foot if the ground is uneven to adjust to the level. Fix the “L” component to the wall where near the ground about 1568mm by M8*60 the bolt. The “L” can match the linking plate hard (as the picture).

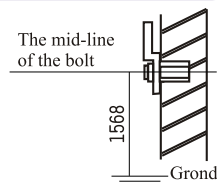

Major technical data

Product model	RTP380E-7	
Power supply	220V~ 50Hz	
Rated input power	1350W	
Interior volume	284L (90L for the upper, 194L for the lower layer)	
The upper layer	Ozone concentration	2mg/m ³ < ozone concentration < 30mg/m ³
	Working time	≥10mins
	Life span for the ozone generator	≥1000h
The lower layer	The sterilizing star	**
	Sterilizing temperature	125°C ⁺⁴ ₋₆ °C
	Working time	≥15mins
Life span for the heat pipe	≥5000h	
Work cycle (load)	≥30mins	
Rated loading weight of each rack	7kg	
Net weight	46kg	
Exterior dimension	555mm×515m×1640mm	
Executive No	GB 17988-2008 Q/KB 16-2010	
Company standard record number	QB/440606 97 9725-2010	
Factory sanitation license	粤卫消证字[2002]第0008号	

Features

- With fashionable outlook design and attractive shape.
- Stainless-steel, durable in use.
- Ozone in the upper layer disinfects the colon bacillus and the staphylococcus to some extent, and it is fit for keeping clean the tableware of which is not high temperature resistant.
- With temperature increase to above 120°C, the infrared ray produced in the lower layer can kill 99.9 percent of the colon bacillus, staphylococcus and showing negative effect in the (HBsAg) damaging experiment, but does no side-effect on human health.
- Accurate temperature control and excellent performance. Equipped with over-temperature protection and guarantee that the upper cabinet will stop working when the door is opened. It is reliable and safe; also, the two layers can work separately.

How to use

- Plug the power cord and get ready for work.
- When the lower layer cabinet is working alone, press the “Lower layer” button and the indicator lamp will be on and the lower cabinet starts working on its own. When the temperature is higher than that set by the temperature control, the indicator lamp will be automatically off.
- When the upper layer cabinet is working alone, press the “Upper layer” button and the indicator lamp will be on and the upper cabinet starts working on its own. When the temperature is higher than that set by the temperature control, the indicator lamp will be automatically off.

- If you want to use the two layer cabinet at the same time, just press the “Upper layer” and “Lower layer” button.
- Sterilizing is still in process within 20mins after the indicator lamp is off. Don't open the door or within this period to guarantee the sterilizing effect.
- If you need to cancel any function, please press the “Cut off” button.
- The upper layer will stop working if the upper door is open and will continue working only when the door is closed and press the “Upper layer” button again.

Daily maintenance

- It is suggested to clean the product often. Remember to disconnect the power supply before cleaning. Then use a wet towel with some neutral detergent to wipe off the stain inside or outside of the cabinet, and then, use a dry towel to wipe off the remaining detergent. If the abnormal state appears while using the product, please stop using and pull the plug out.
- The people not the professional are not allowed to maintain the product.

Familiar malfunction and how to handle:

Familiar malfunction	The reason	The method
Stop working	The plug and the socket not in well contact.	Maintain or replacing
	The fuse burn out	Replace the fuse
	The power wire is short circuit	Replace the power wire
The ozone generator fail to work	The door control switch fail to work	Replace the door control switch
	The relay broken	Replace the relay
	The ozone generator broken	Replace the ozone generator
The heat pipe fail to work	The relay broken	Replace the relay
	The temperature control broken	Replace the temperature control
	The heat pipe broken	Replace the heat pipe

Repair or maintenance service

- Within one year after the product is purchased, this company offers repair service free of charge on the interior trouble which is not caused by users.
- If the trouble is made because of abnormal use or abnormal maintenance, this company would provide repair work at favorable terms. So don't tear off the products serial number tag so that the repair technician may check and record.
- If the repair or maintenance service is required, please contact the after-sale service department of the company.

Product warranty card

NO.:

Product model: _____ Bar code: _____

Invoice number: _____ Buying date: _____

User's name: _____ Phone number: _____

Address: _____

- I、The warranty card should be enclosed in the packing and taken care by the customer as the warranty for the product.
- II、The rules of warranty
 - ① The period of warranty is one year, our company will provide the service of maintain.
 - ② The period of warranty mean that the date showed on the invoice. If you miss the invoice, then, we will according to the bar code and check the date of leaving factory. The warranty date will be 15 days after leave factory date.
 - ③ In the warranty date, the following situation will not be regarded to the free maintain.
 - (1) Can not supply the valid buying bill.
 - (2) The fault is cause by which the user have not install or use the product properly as the user manual showed.
 - (3) The damage is caused by the user who maintain the product by him/herself or use inappropriately.
 - (4) The fault is not cause by the quality of the products but by man-made.
 - ④ The product which is not in the range of free maintain will charge normally.
 - ⑤ Please carry your < Canbo warranty card > and the valid bill.
 - ⑥ If you need to replace your problem product, please supply the copy of the valid bill.
- III、If the user have any problem with the after service, please contact our company directly.

Add: NO.268 Qixin Rd, Xingtian, Shunde City Guangdong Province

PC: 528325

TEL: (0757) 27771526

FAX: (0757) 27773237

Http://www.canbo.cn

E-mail: kbc_service@canbo.cn

Warranty form

Name of the product		Model NO		
The installation department		The installation date		
Bar code of the product (Fill)				
Repair date	Content of fault		Repair department	Repairer
	State of fault	The spare parts		

Notice :
 The repairer should fill the form after repair the fault product in the warranty date